

## Self Retracting Lifelines with Recovery Winch

IKAR SAVERLINE



### Saverline - SRLR STU A S 12 STA

The Saverline - SRLR STU A S 12 STA, aluminium housed fall arrest block with Rescue/Recovery is a sturdy, low maintenance device fitted with a steel rope. The attachment anchorage point on the SRLR STU A S 12 STA is an open steel handle. When a person suffers an accident such as loss of consciousness, they need to be rescued quickly and safely. The inbuilt inertia wheel recovery mechanism can be engaged by pulling the pin on the side of the block and engaging a winding handle. This then allows the device to be used to lift or to lower the casualty to safety and can be used as a retracting device to pull the person back up to safety. Alternatively, a second person can be clipped-in to ascend into the shaft, to rescue the injured person.

|                               |   |
|-------------------------------|---|
| <b>Lifeline Material</b>      | Galvanised Steel Cable  |
| <b>Lifeline Length</b>        | 12 m  |
| <b>Lifeline Width</b>         | Ø 4.8 mm  |
| <b>Attachment point</b>       | Steel Handle  |
| <b>Weight</b>                 | 7 kg  |
| <b>Capacity Load</b>          | 136 kg  |
| <b>Dimensions (LxWxD)</b>     | 450 x 195 x 180 mm  |
| <b>Anchor Hook</b>            | STU   |
| <b>Connection</b>             | 2002206   |
| <b>Arrest Force</b>           | < 6 kN  |
| <b>Edge Tested</b>            | Not suitable for use over a leading edge and has not been edge tested due to winching feature |
| <b>Body Material (ext)</b>    | Aluminium   |
| <b>Chassis Material (int)</b> | Stainless Steel   |
| <b>Certification</b>          | EN 360, EN 1496, ANSI/ASSE Z359.1-2007, ANSI/ASSE Z359.14-2014 *1                             |
| <b>Temperature range</b>      | -40° C to + 50° C   |
| <b>Lifespan</b>               | 10 Years  |
| <b>Global Item Number</b>     | 2002363   |
| <b>Manufacturer Number</b>    | HRA 12  |
| <b>Mounting Bracket</b>       | XTIN2374 - Bracket to fit device to Xtirpa and Tripod   |

**Please note:** The winch is only for rescue. For general hoisting purposes with material loads, or with persons, winches are needed with dedicated certifications.

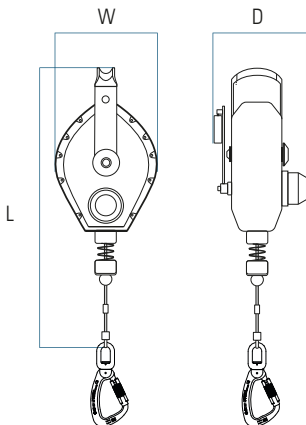

Australia Wide Sales & Service

sales@materialshandling.com.au | www.materialshandling.com.au | 1300 65 00 35

**MATERIALS**  
Handling PTY LTD Working with ease.



### Saverline - SRLR STU A S STA Series

The Saverline - SRLR STU A S STA Series, aluminium housed fall arrest block with Rescue/Recovery is available in different lengths. Please note: The winch is only for rescue. For general hoisting purposes with material loads, or with persons, winches are needed with dedicated certifications.

| Part Number                | Lifeline Length | Weight             | Dimensions (L x W x D) | Global Item Number | Manufacturer Number | Xtirpa/Tripod Bracket |
|----------------------------|-----------------|--------------------|------------------------|--------------------|---------------------|-----------------------|
| <b>SRLR STU A S 18 STA</b> | 18 m            | 11.5 kg            | 570 x 240 x 200 mm     | 2002380            | HRA 18              | XTIN2375              |
| <b>SRLR STU A S 24 STA</b> | 24 m            | 16 kg              | 630 x 275 x 220 mm     | 2002381            | HRA 24              | XTIN2376              |
| <b>SRLR STU A S 30 STA</b> | 30 m            | 21 kg              | 640 x 315 x 230 mm     | 2002382            | HRA 33              | XTIN2377              |
| <b>SRLR STU A S 42 STA</b> | 42 m            | 40 kg              | 740 x 370 x 235 mm     | 2002383            | HRA 42              | XTIN2378              |
| <b>SRLR STU A S 65 STA</b> | 65 m            | 780 x 390 x 240 mm | 2002384                | HRA 65             | N/A                 |                       |



**Please note:** The winch is only for rescue. For general hoisting purposes with material loads, or with persons, winches are needed with dedicated certifications.



SRLR STU A S 65 STA

