

ROLL PRONGS FORKLIFT CARRIAGE MOUNT

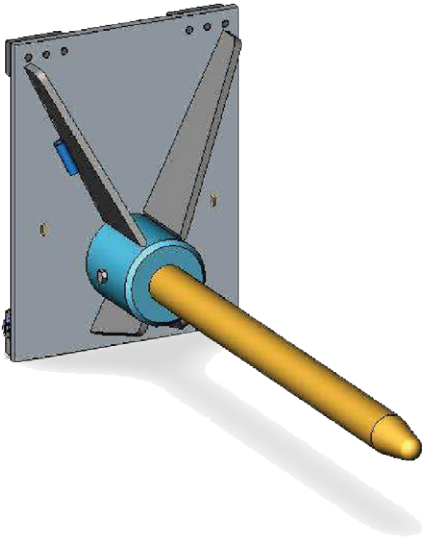

The MRPC Class 3 Carriage Mounted Roll Prong is designed for the safe handling of rolled products with a central core by a forklift with class III carriage.

Features:

- Suitable for carpet, vinyl, fabric, cable, reel, coil and similar products
- Features quick release lower carriage hooks and a spring loaded locating pin for safe & easy installation to a class III forklift carriage
- Manufactured from high tensile steel
- Also available in Class II (QR2) forklift carriage and pin mounted (M series) models
- Custom prong lengths available on request
- Enamel paint finish

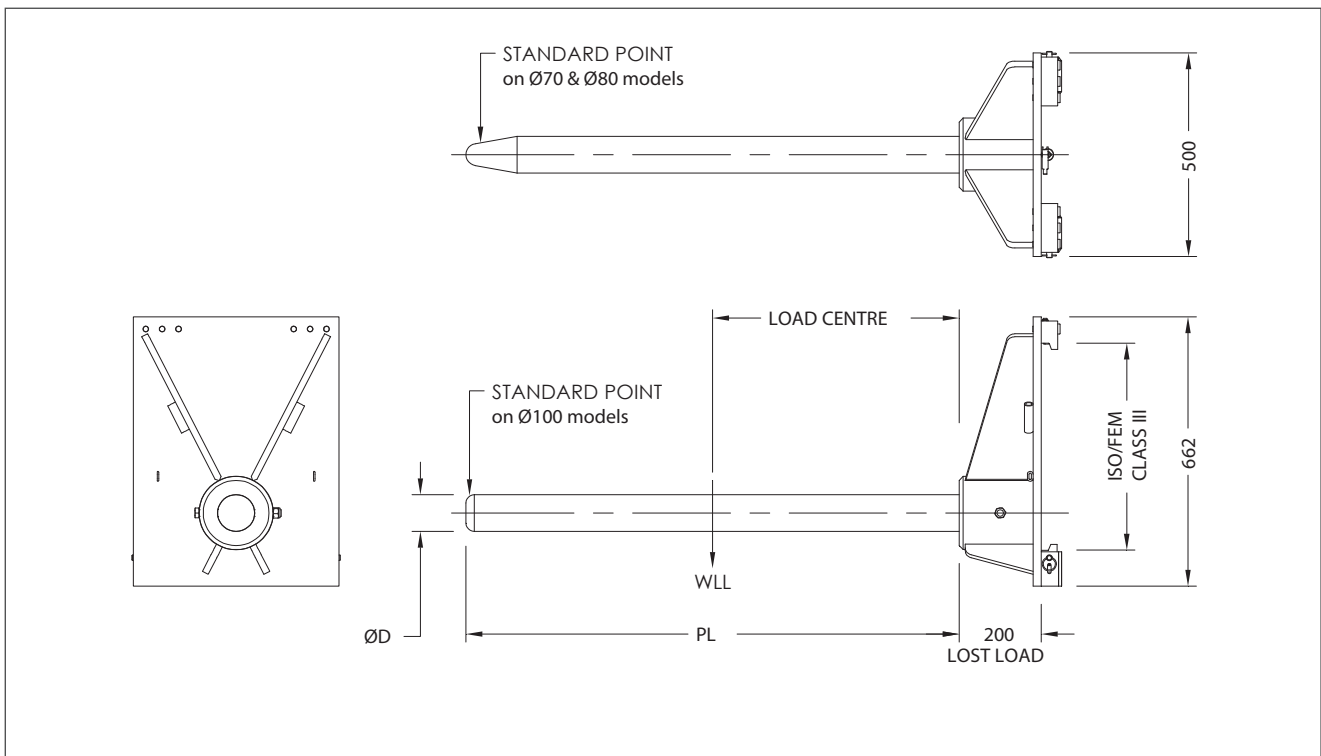

Model	Mounting Class	WLL @ LC (kg @ mm)	Prong DIA (mm)	Prong Length (mm)	Lost Load (mm)	Unit Weight (kg)
MRPC70-2700	Class 3	530 @ 1350	70	2700	200	190
MRPC80-2700	Class 3	890 @ 1350	80	2700	200	215
MRPC100-2800	Class 3	1700 @ 1400	100	2800	200	282