

ROLL PRONGS FORKLIFT CARRIAGE MOUNT

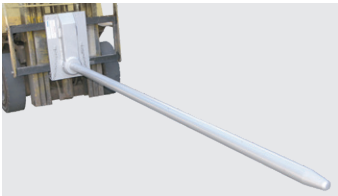
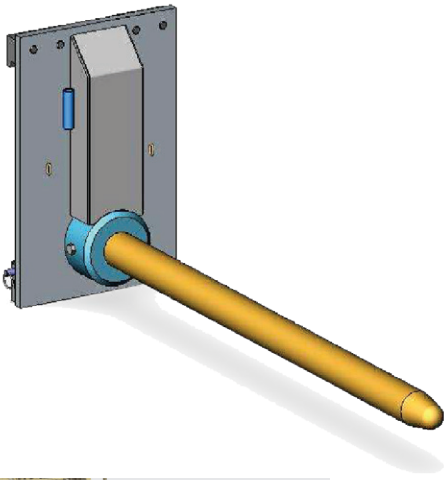

The MRPC Class 2 Carriage Mounted Roll Prong is designed for the safe handling of rolled products with a central core by a forklift with class II carriage.

Features:

- Suitable for carpet, vinyl, fabric, cable, reel, coil and similar products
- Features quick release lower carriage hooks and a spring loaded locating pin for safe & easy installation to a class II forklift carriage
- Manufactured from high tensile steel
- Also available in Class III (QR3) forklift carriage and pin mounted (M series) models
- Custom prong lengths available on request
- Enamel paint finish

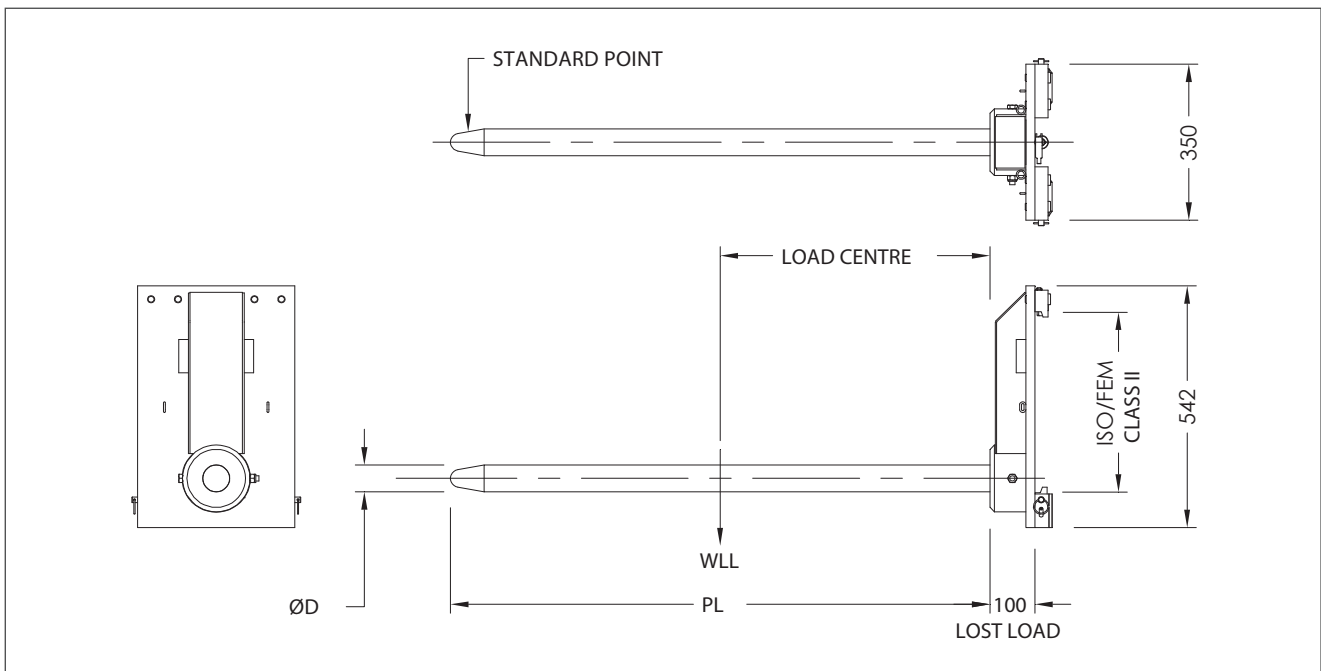

Model	Mounting Class	WLL @ LC (kg @ mm)	Prong DIA (mm)	Prong Length (mm)	Lost Load (mm)	Unit Weight (kg)
MRPC40-1200	Class 2	200 @ 600	40	1200	100	63
MRPC50-1800	Class 2	250 @ 900	50	1800	100	79
MRPC60-2800	Class 2	340 @ 1400	60	2800	100	113
MRPC70-2800	Class 2	510 @ 1400	70	2800	100	135
MRPC80-2800	Class 2	850 @ 1400	80	2800	100	160

Australia Wide Sales & Service

sales@materialshandling.com.au | www.materialshandling.com.au | 1300 65 00 35

MATERIALS
Handling PLY LTD *Working with ease*