

PIPE TROLLEY STORAGE RACK SPECIFICATIONS



BAPV100 Pipe Trolley is designed to safely store and transport long length materials. These mobile storage solutions increase worker productivity by keeping materials organised and close to work areas.

FEATURES:

- Suitable to store and transport long materials such as pipe, conduit, tubing & bar stock
- Designed to fit through a standard doorframe for carting of loads on-site
- Removable V Frame for alternative loading requirements
- Removable corner posts supplied to suit higher load sizes
- 6 industrial 150mm poly/cast wheels with brakes supplied for easy manoeuvring around the worksite
- Also available in all terrain model (BAPV100-AT) fitted with 2 puncture proof wheels for use on rough, uneven ground
- Fork stirrups allow loaded trolley to be transported by forklift
- 4 tie down points available for securing load
- Heavy duty construction for maximum stability
- Zinc finish

Supplied standard as flatpack for on-site assembly.



Working Load Limit (WLL)	1000kg
Dimensions	1640(l) x 760(w) x 640(h) mm
Unit Weight	85kg (incl. V-Frame + Corner Posts)
Fork Stirrup Size	155 x 55mm
Fork Stirrup Centres	850mm

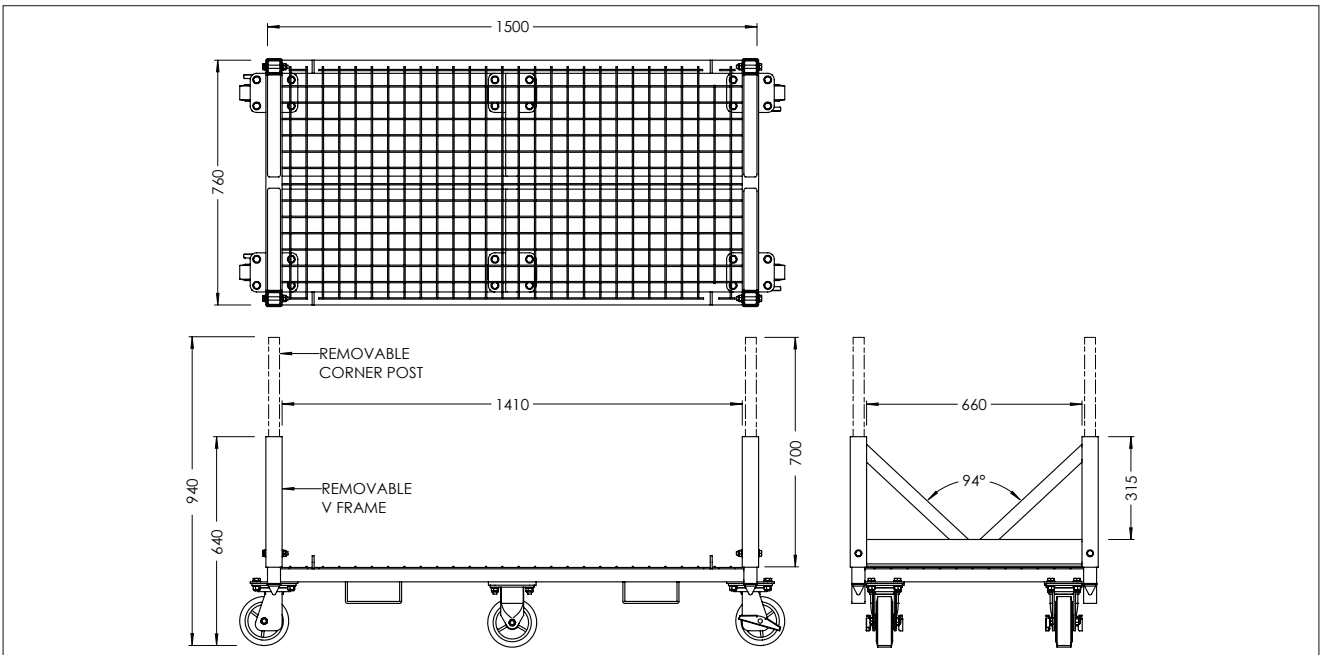

NOTE: Due to transport safety requirements, wheels are supplied for fitment onsite - not pre-fit.

Australia Wide Sales & Service

sales@materialshandling.com.au | www.materialshandling.com.au | 1300 65 00 35

MATERIALS
Handling *Working with ease*
PTY LTD