

PIPE TROLLEY STORAGE RACK SPECIFICATIONS

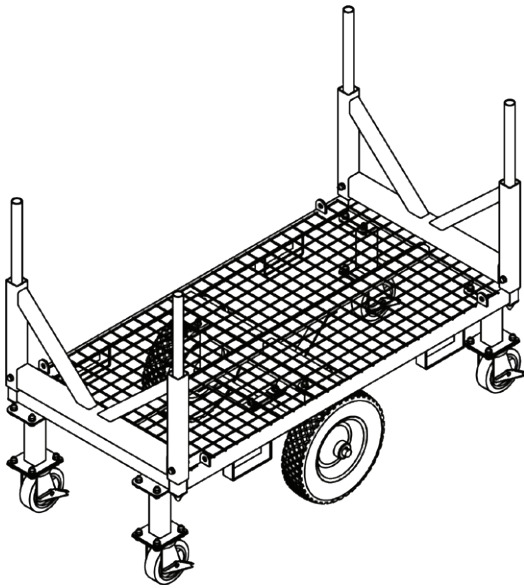

BAPV100-AT All-Terrain Pipe Trolley is designed to safely store and transport long length materials and is ideal for use on rough, uneven grounds. This mobile storage solution increases worker productivity by keeping materials organised and close to work areas.

FEATURES:

- Suitable to store and transport long materials such as pipe, conduit, tubing & bar stock
- Designed to fit through a standard doorframe for carting of loads on-site
- Removable V frame for alternative loading requirements
- Removable corner posts supplied to suit higher load sizes
- 6 wheels (2 puncture proof 390mm + 4 x 150mm swivel with brakes) for use on rough, uneven grounds
- Also available in model (BAPV100) with 6 poly/cast 150mm wheels for easy manoeuvring around the factory
- Fork stirrups allow loaded trolley to be transported by forklift
- 4 tie down points available for securing load
- Heavy duty construction for maximum stability
- Zinc finish

Supplied standard as flatpack for on-site assembly.



Working Load Limit (WLL)	400kg
Dimensions	1640(l) x 760(w) x 860(h) mm
Unit Weight	95kg (incl. V-Frame + Corner Posts)
Fork Stirrup Size	155 x 55mm
Fork Stirrup Centres	850mm

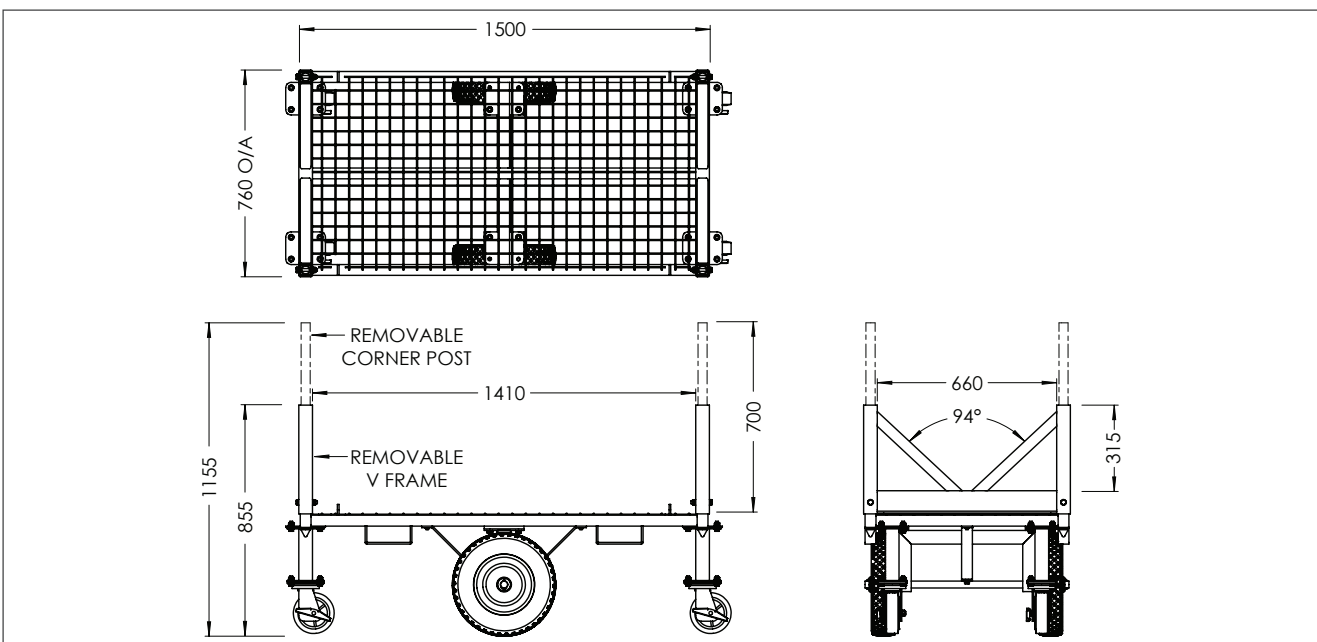

NOTE: Due to transport safety requirements, wheels are supplied for fitment onsite, not pre-fit.

Australia Wide Sales & Service

sales@materialshandling.com.au | www.materialshandling.com.au | 1300 65 00 35

MATERIALS
Handling *Working with ease.*
PTV LTD