

MATERIALS
Handling *Working with ease...*
PTY LTD

PALIFT

SERIES 3 PALLET LEVELLER



Loading pallets with Palift is one of the best ways to save workers backs...

By automatically keeping a pallet or stillage at the optimum working height when loading or unloading goods, Palift dramatically reduces the effort required to palletise goods. Our proven design is incredibly robust and can endure more than 15 years of daily use without maintenance.



How does Palift work?

Pallet Levellers resemble scissor lift tables in appearance. They have a top deck and a base connected by a pair of scissor legs. The levelling mechanism is a set of springs set to the weight and height (the density) of the product. Pallet levellers work automatically and raise or lower as the weight changes.

Load setting is a simple process and for most users springs never have to be changed. A shock absorber prevents any bounce and all Australian Palifts are supplied with a standard galvanised finish

Palift Applications.

Durable and tough, Palift can be used in a wide range of applications including warehousing, wash down and other harsh environments. With more than 120,000 users worldwide, Palift is the simplest and most effective solution to manual handling problems created when loading and unloading pallets.

Palift Series 3

The original and best way to load pallets

Key Features & Benefits:

1. Load Safe profile — ergonomic loading and unloading
2. Automatic levelling ensures optimum working height is maintained at all times
3. Virtually eliminates lifting, bending and stretching, the primary causes of back injuries

- ✓ Set and forget Springs
- ✓ Turntable top for easy load rotation
- ✓ Plastic safety top protects hands and fingers¹
- ✓ Mobility trolley²
- ✓ Adjustable Feet²

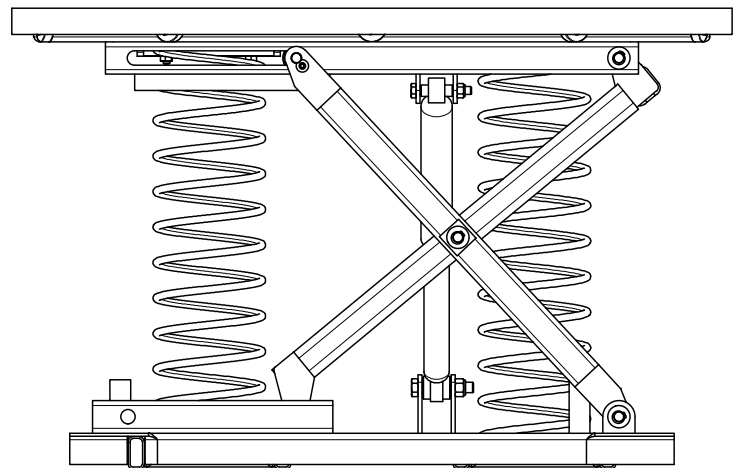

- ✓ No power or maintenance required
- ✓ Turntable Rotation Lock²
- ✓ WLL up to 2000kgs
- ✓ Forklift Tyne sockets

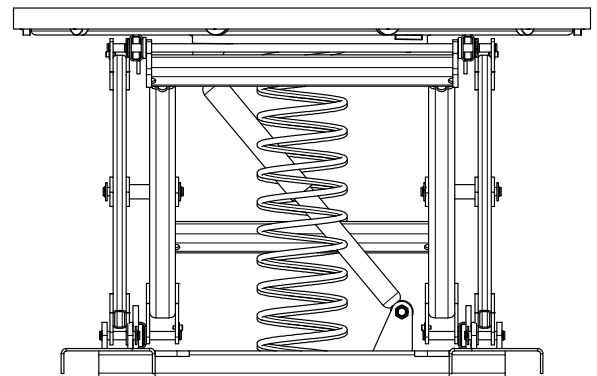

1. Only applicable on MCH3 model
2. Available to order as an optional extra

Palift Specifications

Palift Series 3		MCH3	MCH1
1.1	Maximum Working Capacity kilograms	2000	2000
1.2	Maximum Height (extended height) millimetres	709	709
1.3	Minimum Height (compressed height) millimetres	239	225
1.4	Turntable Diameter millimetres	1100	N/A
1.5	Square Top dimension millimetres	1046 x 1060	
1.6	Turntable Lock (optional)	Y	N/A
1.7	Durable Fully Galvanised Frame	Y	Y
1.8	Product Weight kilograms	150	150
1.9	Palift Stainless Steel Option	POA	POA

Palift MCH3



Palift MCH1



Palift Accessories		Part
2.1	Mobile Base Frame (galvanised only)	MCH9
2.2	Mobile Base frame Handle (galvanised only)	MCH10
2.3	Adjustable Feet (set of 4)	MCH11
2.4	Turntable Rotation Lock	MCH12