

GAS BOTTLE TROLLEY MGC2 DIMENSIONS

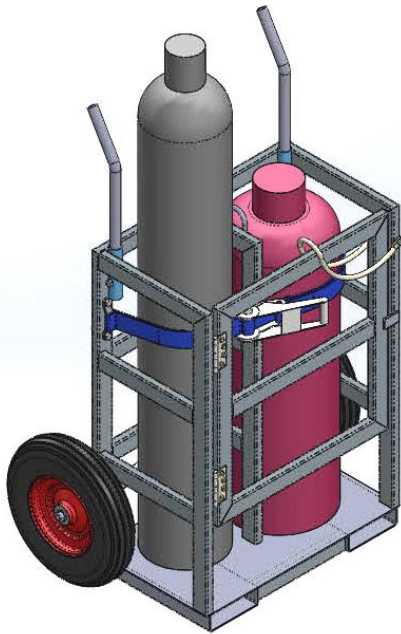

Gas Cylinders not included



Crane Sling provided

The type MGC2 Gas Bottle Trolley has been designed to suit one type 'G' Oxygen and one type "G" Acetylene gas cylinder. Provision has been made to store all hoses inside the cage. The cage is supplied with an internal loadbinder to securely fasten both cylinders. Fitted with Handle and 400 mm air inflated rubber wheels, this cage can be transported manually, by Forklift or by Crane.

SPECIFICATIONS:

- Single point lift
- 1T Lifting Crane Sling provided – 690 mm long
- Working Load Limit (WLL): 250 kg
- Unit Weight: 55 kg
- Integrated Fork Pockets 165 x 45 mm
- Fork Pocket Centres: 480 mm
- Painted Enamel Chassis/Rims
- All other components – Zinc Plated

