

BULK BAG HOPPER MSKH200 SPECIFICATIONS

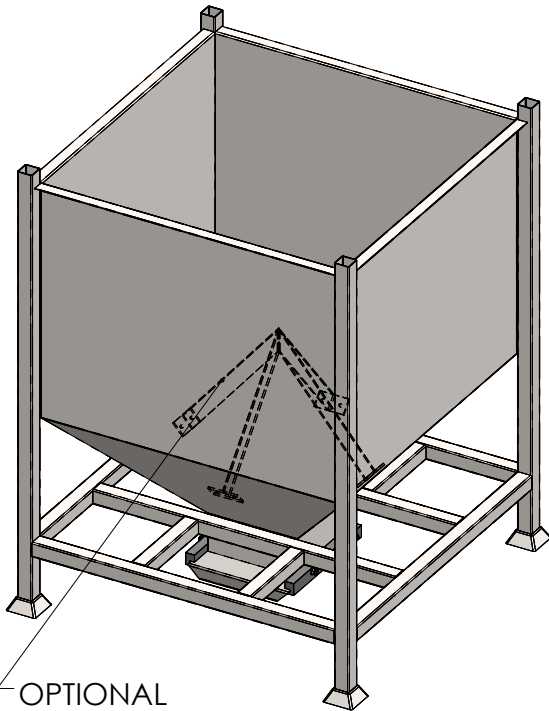

OPTIONAL
BAG PIERCING KNIFE

The MSKH200 Bulk Bag Hopper is designed for filling bulk bags with soil, sand, gravel, dirt and similar materials.

By using this item along with a MSKX100 Bulk Bag Frame, the bulk bag will be kept open under the Hopper's chute for a hands-free filling operation. The hopper chute is fitted with a stainless steel gate which slides in a Polyethylene rail. An optional Bag Piercing knife (MSKH-BP) can be ordered separately for ease of piercing source bags and discharging of materials into the hopper. The hopper is fitted with stacking feet to allow stacking 2 high in its standard configuration.

SPECIFICATIONS:

Working Load Limit (WLL): 1000kg

Unit Weight: 165kg

Volume: 1 cu.m

Finish: Zinc

