

CRANE DRUM ROTATOR DCDR1000H SPECIFICATIONS

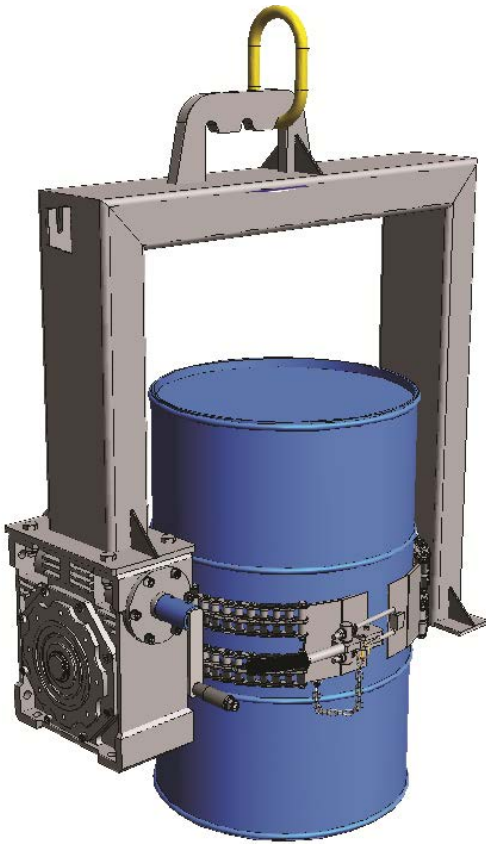

Drum not included, for illustrative purposes

The heavy lift capacity DCDR1000H Crane Drum Rotator is designed to lift and rotate 205 litre steel drums by overhead crane. Rotation of the drum is controlled throughout the operation by the handle driven gearbox which locks the drum in position when operator stops turning the handle, preventing dangerous and uncontrolled movements.

Features:

- Empties a standard 205 litre drums with minimal effort
- Heavy lift capacity allows 360° rotation of drum up to 1000kg
- Suitable for drum rotation up to chest height
- Rotation carried out via a hand crank
- Belly strap and eccentric lock secures drum in position
- Locking pin prevents accidental release during tipping cycle
- Large worm drive gearbox provides automatic braking
- Suits mining operations, manufacturers and foundries
- Also available in model (CDR1000C) with a chain driven gearbox for rotation up to 3m above ground
- Zinc finish

Working Load Limit (WLL)	1000kg
Rotation	360°
Rotation Shaft CL to Lifting Eye	1200mm
Unit Weight	220kg

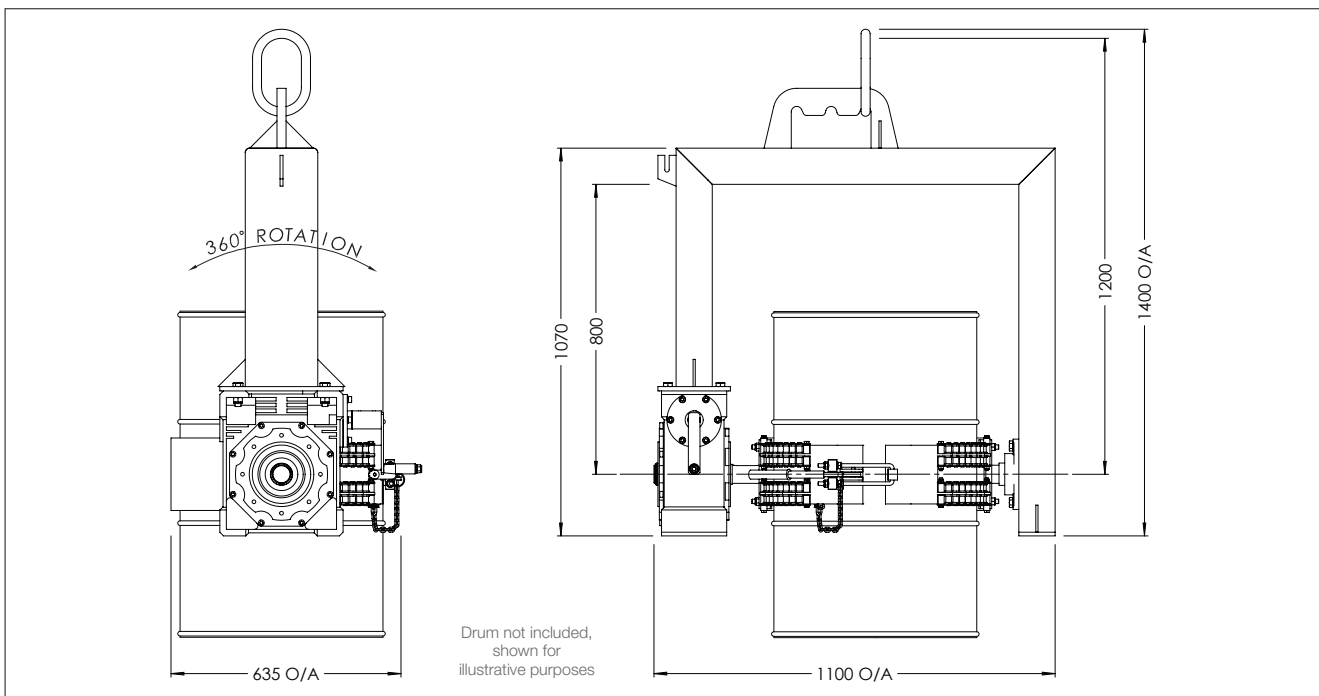

Australia Wide Sales & Service

sales@materialshandling.com.au | www.materialshandling.com.au | 1300 65 00 35

MATERIALS
Handling PTV LTD Working with ease™