

CONCRETE KIBBLE LAYDOWN CKROF20

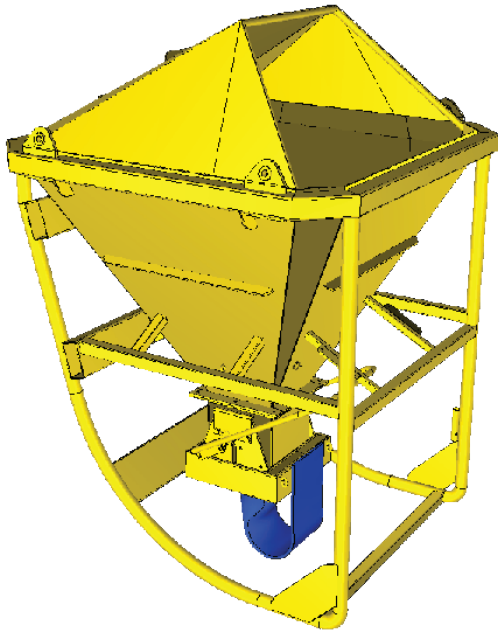

The CKROF20 Concrete Kibble is a heavy duty, roll-over style for easy transfer of concrete on site by overhead crane.

Features:

- Suits large applications requiring up to 2m³ capacity
- Roll-over (laydown) style allows filling from concrete dispensing chute
- Fitted with a lever operated 400 x 400mm clamshell gate with auto close
- Removable concrete funnel with 2m lay-flat hose allows controlled flow when filling wall cavities, columns or narrow formwork
- 4 point lift crane lugs fitted to increase safety and reduce weight
- Fork pockets fitted for transport around the work site when empty
- Hydraulic Kibble Option (HPP-REMOTE) available to remotely control kibble
- Also available in models with a manual or hydraulic 200mm dia slide valve (CKROF20-SV / CKROF20-SVH) for precise concrete flow control
- Enamel paint finish

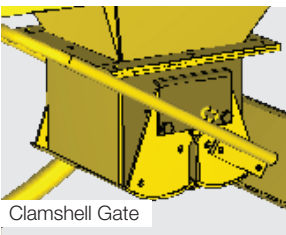

Clamshell Gate

Working Load Limit (WLL)	5000kg
Volume	2.0cu.m
Filling Height	1380mm
Laydown Dimensions	2965 x 2010 x 2000mm
Funnel Hose	Ø200mm x 2m long
Unit Weight	780kg (including funnel)
Fork Pocket Size	185 x 85mm
Fork Pocket Centres	750mm

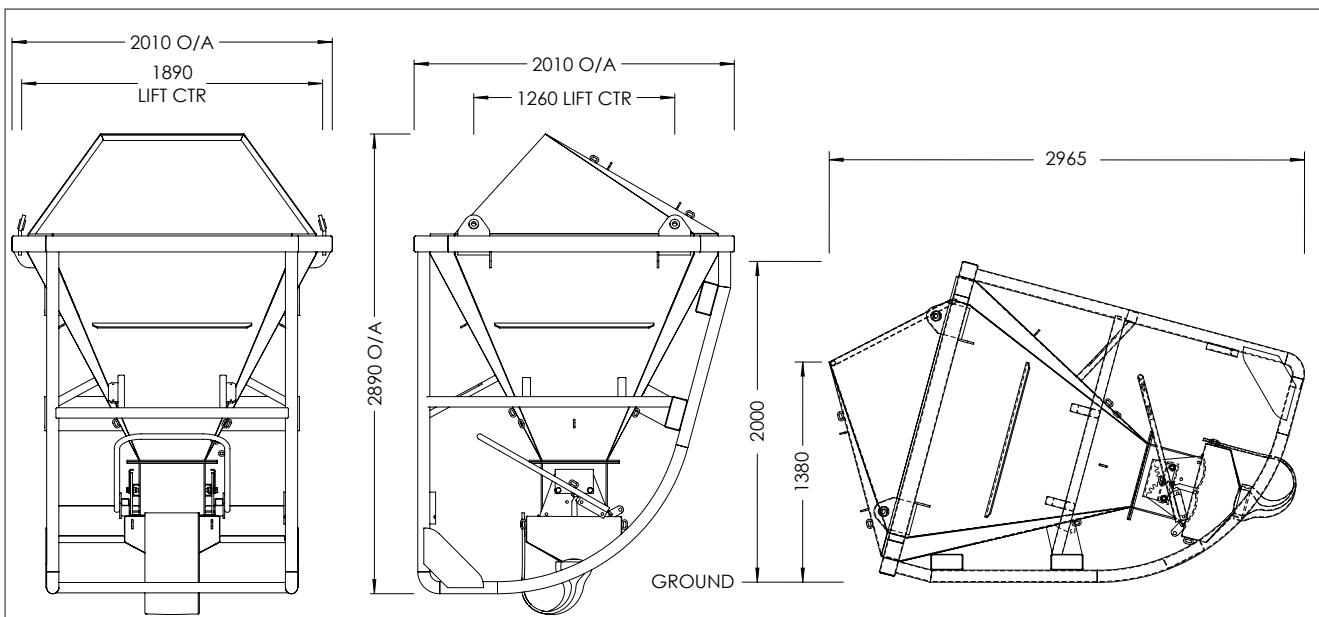

Australia Wide Sales & Service

sales@materialshandling.com.au | www.materialshandling.com.au | 1300 65 00 35

MATERIALS
Handling *Working with ease.*
PTV LTD