

# BULK BAG LIFTING FRAME SPECIFICATIONS



The FBCS15 Bulk Bag Lifter is a slip-on attachment for lifting, loading and transporting loaded bulk bags by forklift. Designed for flexibility, this unit can be separated for direct carriage use.

## Features:

- Allows bulk bags to be easily moved around the worksite or loaded into a container
- Bulk bag is secured via 4 hooks on upper frame for safer handling
- Designed to maximise lift height
- Slip-on carriage converts the lifting frame (and other carriage mount attachments) into a slip-on attachment for quick, easy connection to the forks of a forklift
- Spring loaded locators and quick release bottom hooks are fitted to the lifting frame for fast connection to a fork carriage
- Enamel paint finish



Lifting Frame with fork carrier brackets fitted allows mounting to a fork carriage

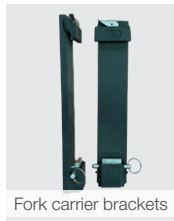

Fork carrier brackets

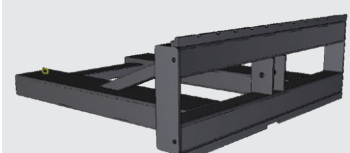

Slip-on Carriage allows attachment to be connected to the forks of a forklift

|                          | FBN15-QR2 Lifting Frame | FNSC2 Slip-on Carriage | FBCS15 Combined unit |
|--------------------------|-------------------------|------------------------|----------------------|
| Mounting Class           | Class II                | -                      | Class II             |
| Working Load Limit (WLL) | 1500kg                  | 2500kg                 | 1500kg               |
| Hook Centres             | 880 / 800mm             | -                      | 880 / 800mm          |
| Unit Weight              | 126kg                   | 93kg                   | 219kg                |
| Fork Pocket Size         | -                       | 180 x 60mm             | 180 x 60mm           |
| Fork Pocket Centres      | -                       | 700mm                  | 700mm                |
| Horizontal C of G        | 225mm                   | 840mm                  | 1160mm               |
| Vertical C of G          | 670mm                   | 25mm                   | 275mm                |

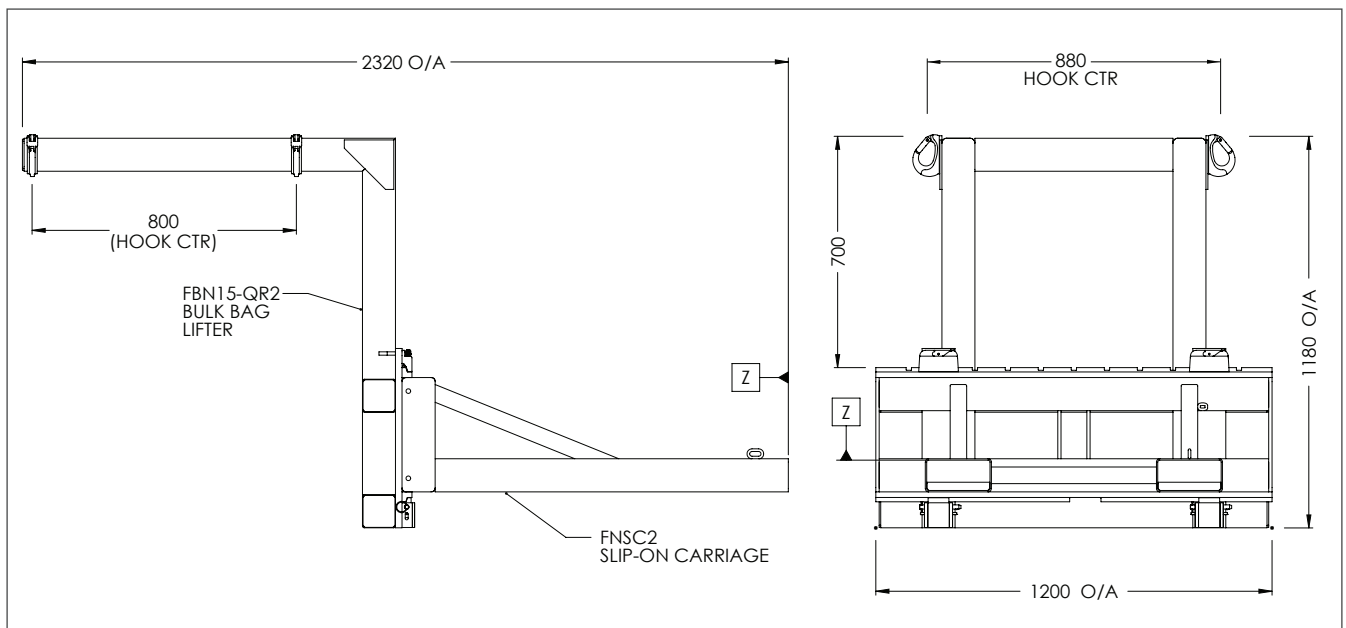

Australia Wide Sales & Service

sales@materialshandling.com.au | www.materialshandling.com.au | 1300 65 00 35

**MATERIALS**  
**Handling** PTY LTD *Working with ease.*