

Hydro-Park 1127

High-end Two Post Parking Lift

PROFESSIONAL PARKING SOLUTION PROVIDER!



WE PLAN , DESIGN, MANUFACTURE AND INSTALL...

Hydro-Park 1127

Two Post Parking Lift 2 Levels

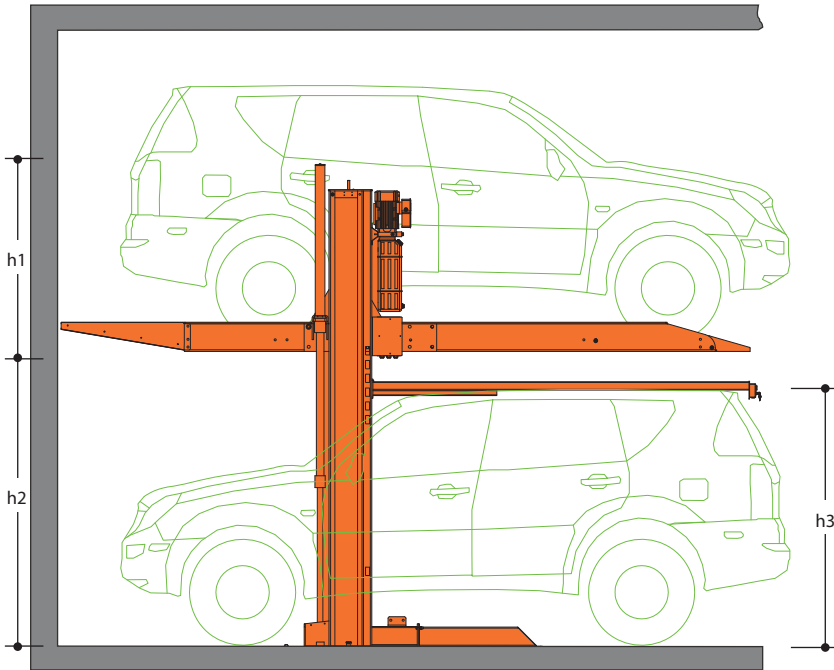

| Hydro-Park | |
|------------|------|
| h1(mm) | 1408 |
| h2(mm) | 2100 |
| h3(mm) | 1865 |

Introduction

Hydro-Park series of products are developed to provide customers more reliable, stable and usable parking equipments. A lot of new designs and components are updated, to make sure the products can work for much longer time with less maintenance.

Hydro-Park 1127 is the new Two Post Parking Lift. It's a kind of valet parking equipment, suitable for both commercial and residential parking purposes. It moves only vertically, so the users have to clear the ground level to get the higher level car down. It is hydraulic driven type that lifted directly by cylinders. The equipment can be used for both sedan & SUV.

- Commercial grade design
- Galvanized and corrugated platform guarantee safety and long lifetime
- Anti-slip corrugated deck protect both vehicle and driver from possible slip and damage but still high-heel shoe friendly
- Dual hydraulic lifting cylinders direct drive
- The pole with piston is chroming to anti-corrode to ensure its long using life
- Individual hydraulic power pack and control panel
- Self-standing and self-support structure
- Symmetrical designed column
- Can be relocated
- Special designed control arm for operator to control the lift without getting under the platform
- Synchronization chain assuring the lifting platform balance
- 2700kg and 2300kg capacity for different demands
- Middle post sharing feature save cost and space
- Electric key switch for security and safety
- Automatic shut-off if operator releases the key switch
- Dynamic mechanical locks as anti-falling device hold the platform in place
- Manual lock release available in case electricity failure
- Platform can be stopped at different heights to fit for various vehicles and ceiling heights
- Hydraulic overloading protection

General Parts

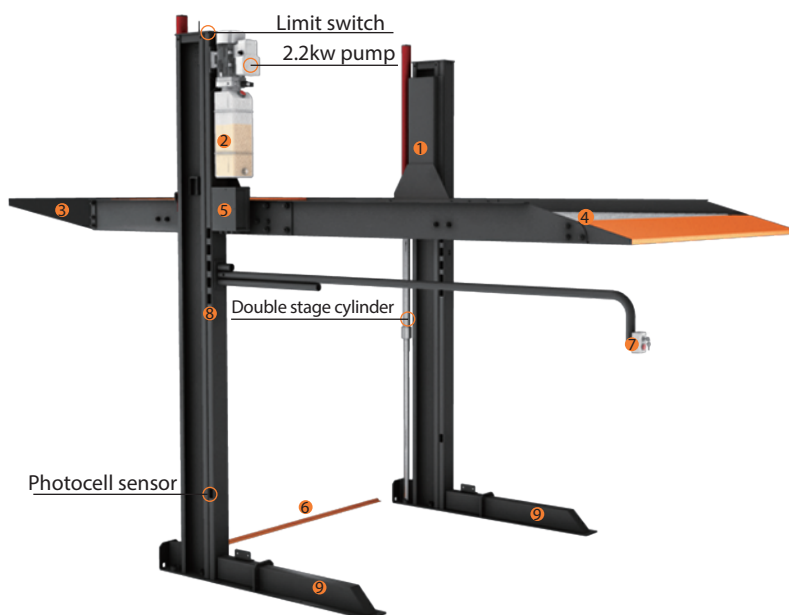

- 1 Carriage
- 2 Transparent oil tank
- 3 Oil drip tray (optional)
- 4 Galvanized cover plate
- 5 Electric box
- 6 Oil pipe protector
- 7 Key switch & emergency stop button
- 8 Dynamic lock
- 9 Front & Back footage

Advantages

We are now proudly represent you our most popular simple parking equipment, the Hydro-Park 1127!

1 Low usage cost

When the platform moves down, it will be driven by gravity, so there is no electricity consumption for hydraulic power pack.

2 Fast and easy installation

With professional design and friendly package, it becomes simple on installation. What's more, detailed installation manual, drawing and video attached with products will help customers have easier installation work.

3 Sharing post feature

The posts could be shared when they are installed side by side, which can save cost, land space, and container space.

4 Professional packing & delivery

We have very professional packaging and logistic people to ensure our customer will get the product damage free, simple load & unload in time.

5 Hydraulic driving mode

Thanks to the hydraulic driving mode, our lift could have a faster lifting speed. Even though there is power failure, the upper car still can be retrieved by manually operating the solenoid valve.

6 Dynamic locking device

We are offering the safest parking machine in the market, the equipment is built under the CE standard and there are more than 10 safety features to ensure our clients will always get protection. Especially, there are a range of locking tabs on the posts to protect cars from accident damage.

7 Stronger structure

Hydro-Park 1127 enforced the critical parts that carry the weight makes the equipment extra strong.

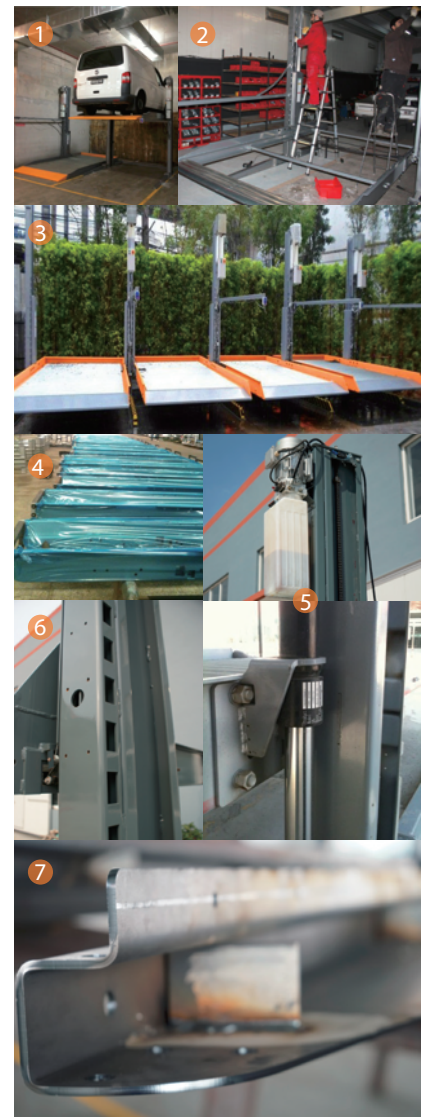

Specifications

| Model | Hydro-Park 1127 |
|-----------------------|--|
| Lifting capacity | 2700kg |
| Equipment weight | 1100kg |
| Lifting height | 2100mm |
| Usable platform width | 2100mm |
| Electrical required | 220-420V, 1 or 3Phase, 50/60Hz *Price maybe different! |
| Control power | 24V |
| Lock device | Dynamic |
| Lock release | Electric auto release |
| Operation | Key switch |
| Power pack | 2.2 kw hydraulic power pump |
| Lifting/lowing time | 50/45 Sec. |
| Finishing | Powder coating |

Operation

Hydro-Park 1127 is a kind of valet parking, it means people need get the bottom car out first then can retrieve the top car if both two cars are parked

1. First car onto platform



2. Moving up of platform



3. Second car into ground space



4. Finished it



Sharing Post Feature



Unit A = 2 posts = independent unit



Unit B = 1 posts = dependent unit 1 unit A + 1 unit B

With the unique design of the Hydro-Park 1127 sharing features, we are providing you following advantages:

- Less overhead cost
- Less width required
- Less installation job needed
- Less delivery cost
- Stronger structure



Before sharing: 5 unit A with 10 posts

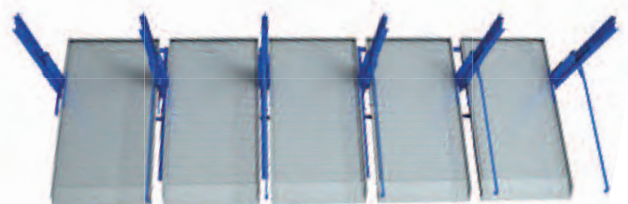

After sharing: 1 unit A + 4 unit B, just 6 posts

Head In

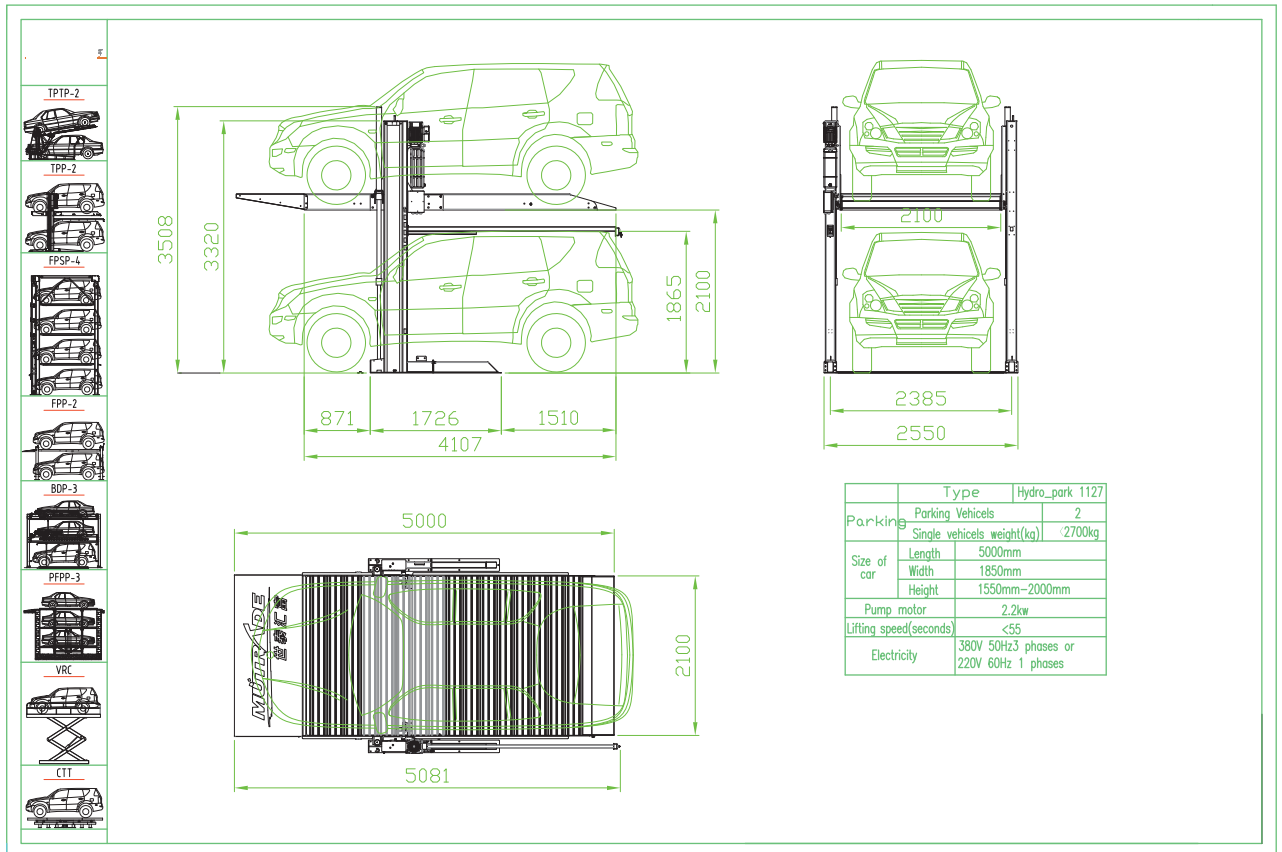

Back In

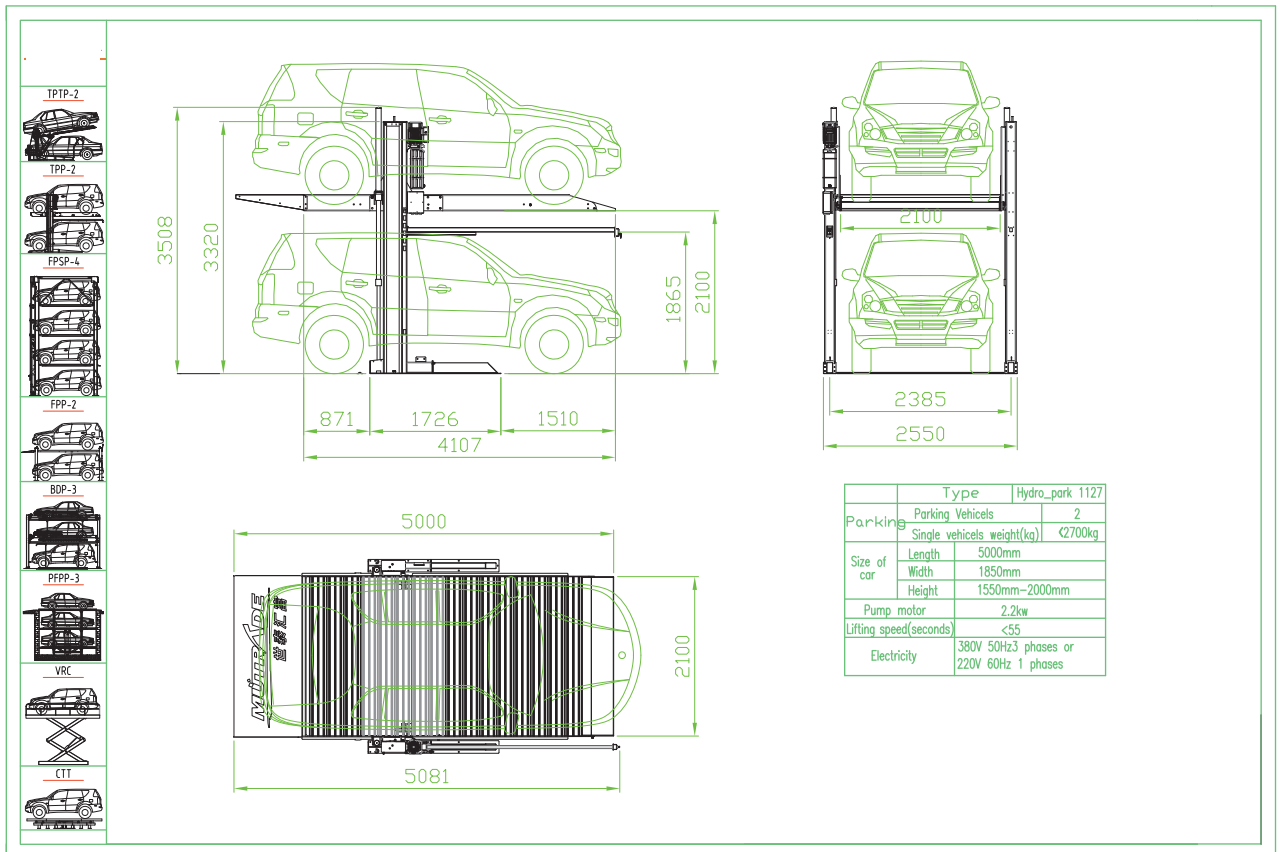

Width calculation



2550

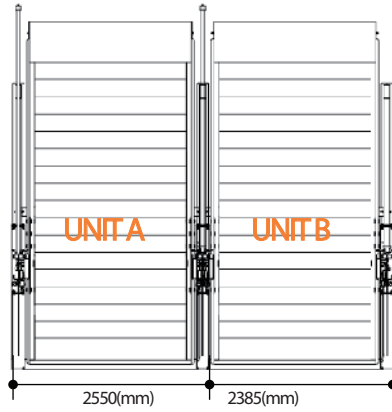

4935

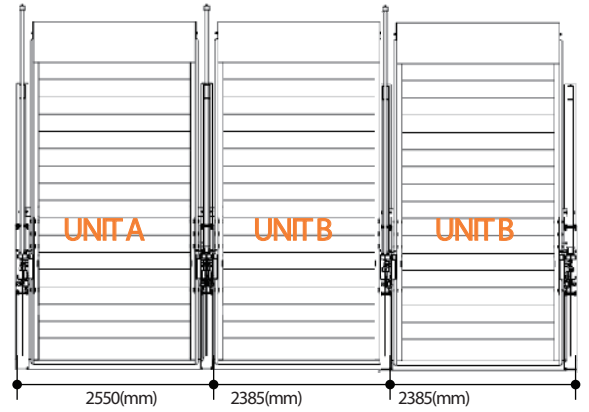

7320

Electrical & hydraulic diagram

Electrical diagram (24V)

Hydraulic diagram

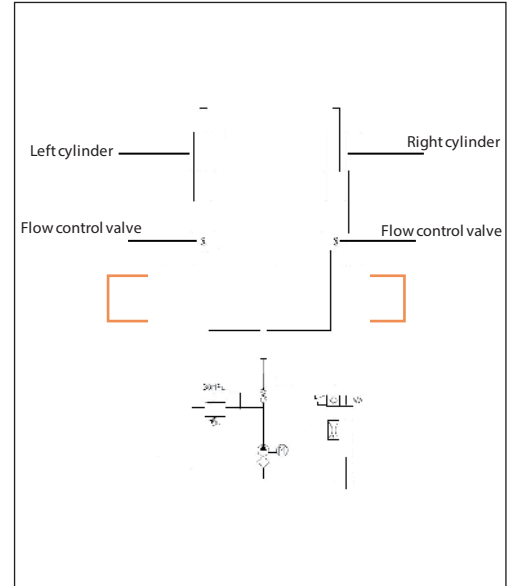
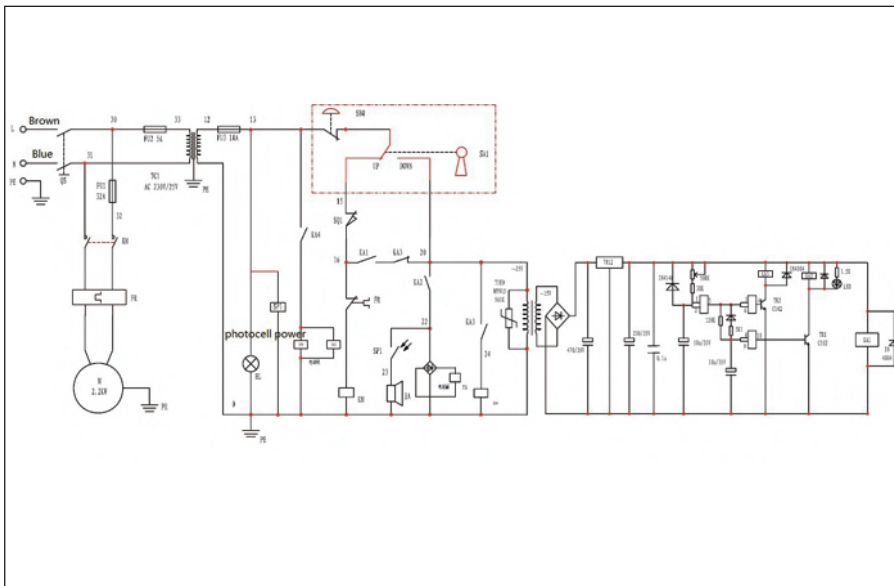

Packaging & container loading

Surface Finishing



| Models | Hydro-Park 1127 |
|----------------|-----------------|
| Unit A in 20ft | 7 unit |
| Unit A in 40ft | 18unit |
| Unit B in 20ft | 9 unit |
| Unit B in 40ft | 24unit |

Powder coating is applied as a free-flowing, dry powder. It is typically applied electrostatically and is then cured under heat to allow it to flow and form a "skin". It is usually used to create a hard finish that is tougher than conventional paint.

Safety Features

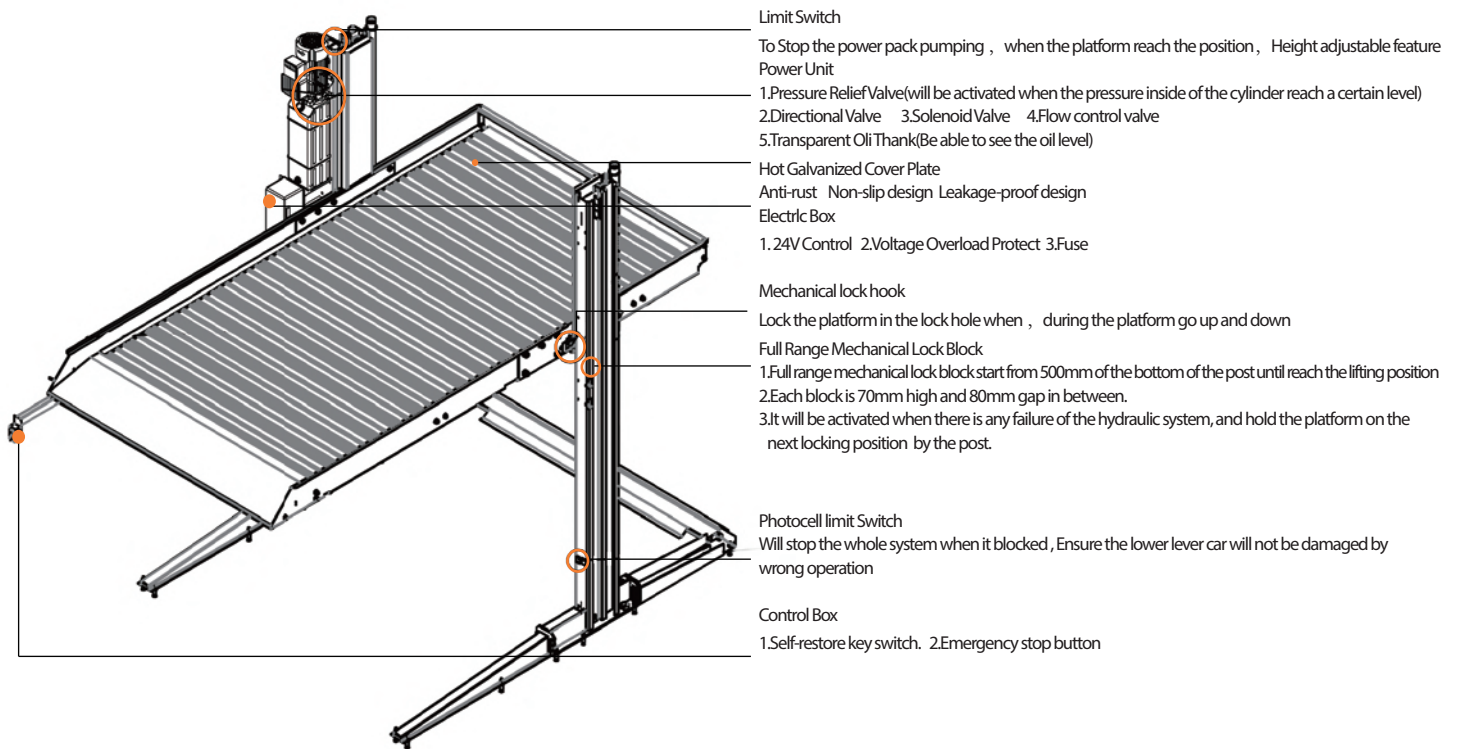

- "All the way" 6 mechanical safety lock every 10cm
- 24v electric lock release (no harm for operator)
- Photocell sensor available to check under car and avoid trespass.
- Electric protection for power over load or under voltage.
- Auto locking system for power cut as safety features.
- Emergency stop button.
- Pressure relief valve and pressure compensate flow control valve to triple ensure safety.
- Limited switch in the top of the post (when the platform go to the appointed height, it will automatic stopped to avoid the wrong operation)
- Photocell switch installed in the post of 50 cm above the ground (when a child pass, this photocell is blocked, then the whole equipment is stopped to avoid harming children)
- Italian hydraulic seal to ensure the total quality of Hydraulic cylinder
- Overload protection device for hydraulic power pack
- Besides the synchronization chain (5 times than weight capacity), Platform pull-rod double ensure its balance.

Mechanical Anti-falling Locking



- Dynamic locking device
With 6 locking tabs



- Electromagnet



Operating Instructions

⚠ WARNING

To avoid death, personal injury and/or property damage, permit only trained personnel to operate lift and accessories. Adult operation is required.

After reviewing these instructions, get familiar with lift controls by running the lift through a few cycles before loading a vehicle on lift.

⚠ SAFETY Observe and heed all CAUTION, SAFETY and WARNING LABELS on the lift. Keep clear of lift while it is being raised or lowered. The platform is designed to rest on the floor when fully lowered. Keep feet clear.

1. Loading: Lift must be fully lowered and no one in area while the vehicle is brought on lift.

2. Center vehicle tires on platform and carefully back vehicle onto lift until tire contacts rear wheel stop. Be cautious of low profile vehicles where body may not adequately clear rear wheel stop. In this event back

⚠ SAFETY Driver and passengers must exit before raising lift!

3. To Raise Lift: Turn the key switch clockwise. Release switch at desired height, Fig. 1. ONLY OPERATE ONE LIFT AT A TIME.

IMPORTANT Observe lift, vehicle and overhead clearance as it is raising.

⚠ WARNING Clear area if vehicle is in danger of falling.

4. Before Lowering Lift: BE SURE no one is in the lift area. Remove all obstacles from under vehicle and lift platform.

5. Lowering The Lift:

A.) Turn the key switch counter-clockwise, control system will automatically raise the lift off of the locking latch, approximately 1" to 5"

B.) Keep turning the key switch, control system will automatically release locks through solenoid, Fig. 2., and platform will come down

IMPORTANT The raising time will last for several seconds, please keep turning key switch. The raising time could be adjusted according to installation manual, ONLY BY TRAINED PERSONNEL

Note: Without actuating the lock release lever the lift will only lower onto the locking latch. After you clear the lock bar on the column, you can release the lock release lever and continue to completely lower the lift to the ground.

⚠ SAFETY Before lowering lift be sure no one is in the lift area and that all obstacles have been removed from under the lift.

C.) When platform lower down at the height of 500mm from ground, the buzzer will start to work, please make sure there is nothing under the platform and continue the downward travel

D.) Observe lift and vehicle to make sure they are coming down level. If not, stop and raise the lift until it becomes level again. Check to see if lock lever is releasing all locks. - See trouble shooting.

E.) If your lift is not operating properly, DO NOT use until adjustments or repairs have been made. Contact and authorized lift service professional for repairs.

6. Unloading the lift:

A.) Ensure lift is fully lowered.

B.) Carefully drive vehicle off lift.

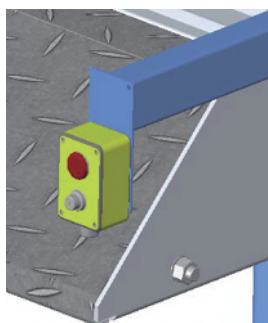

Fig. 1

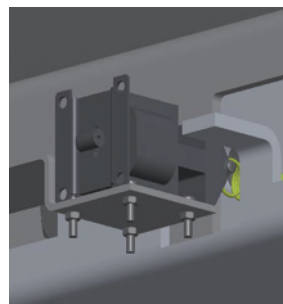
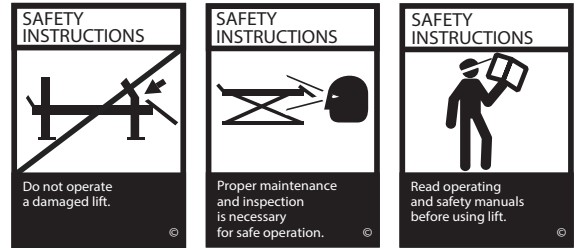

Fig. 2

Safety Instructions

- Policy should prohibit customers or non-authorized persons or bystanders from being in area while lift is in use.
- Thoroughly train all operators of this equipment in the use and care of lift and accessories.
- Be Sure no one is standing in front or behind lift while vehicle is being driven onto or backed off the lift.
- DO NOT permit anyone on lift when it is either being raised or lowered.
- Always stand clear of lift when raising or lowering and observe "Pinch Points" Warnings.
- Never overload lift. Capacity of lift is 7,000 lbs.



CAPACITY SHOULD NEVER BE EXCEEDED!

- Always shut off engine and engage parking gear and brake before exiting the vehicle.
- Always drive on/off lift with care.
- Keep area around lift clean of tools, debris, grease, oil, flammables, etc.
- Always keep lift platform clean.
- Replace all caution, warning, or safety related decals on the lift when unable to read or missing.

Maintenance Instructions

IMPORTANT If you are not completely familiar with automotive lift maintenance procedures, STOP. Contact factory for instructions.

To Avoid Personal Injury, permit only qualified lift service personnel to perform maintenance on this equipment.

- Periodically:
 - Check all column, lift/platform attaching bolts for tightness.
- Always
 - raise lift when cleaning floor area with solvents and/or cleaning compounds.
- Daily:
 - Check chain and sheaves for wear.
- Daily:
 - Check locking latch operation. Adjust per install instructions or repair if required with genuine factory parts.
- Monthly:
 - Check chain tension. Adjust per installation instructions.
- Semi-Annually:
 - and refill if required. If fluid is required, inspect all fittings, hoses and seals. Repair as required. Check fluid level of lift power unit

A. Operation

1. Please pay all your attention on the movement of platform during this equipment works. And stop your operation at once if any toppling of platform is found.
2. Keep holding the key switch to operate the equipment, which will stop at once if your hand releases.
3. Due to top limit switch, the equipment can stop at once if the platform lift up to top position.
4. There are three statuses in descending:
 - (a) The distance of platform to ground is 2100mm (the top position), if you keep turning the key to DOWN: after no movement for 3 to 5 seconds, the mechanical lock will be released automatically then platform start to descend.
 - (b) The distance of platform to ground is less than 2100mm but more than 500mm, if you keep turning the key to DOWN: the platform will lift up for 3 to 5 seconds, then the mechanical lock will be released automatically and the platform start to descend.
 - (c) The distance of platform to ground is less than/equal to 500mm, if you keep turning the key to DOWN: without waiting or lifting, the mechanical lock will be released automatically and the platform start to descend with buzzer and alert light.
5. The inspection on whole equipment is necessary before operation, and make sure your operation is under the condition that all equipment devices work well. Before first operation, firstly please open general power switch, secondly open the power switch on control box, thirdly make sure the emergency stop button on control panel is open.
6. The correct drive direction is forward, It's not allowed for vehicles driven backward onto platform. And make sure vehicle is parked in the middle of platform, and the front tires must reach the car stopper in the back of platform.
7. Over loading is not allowed for vehicle parked on the platform, the rated capacity of Hydro-Park 1127 is 2700kg and maximum capacity is 3000kg.

The wheel base of vehicle parked on the platform should not be more than 2900mm.
The total height of vehicle parked under platform should not be more than 2000mm.
8. It's not recommended if no vehicle is on the platform in operation.
9. The power indicator light is off until both general power switch and power switch on control box is opened, which will make the circle of whole control system on.

B. Maintenance

1. Do lubrication on guide rail and guide pulley once per month.
2. Do lubrication on balance chain once per month.
3. Change all the hydraulic oil three months after first operation; and change oil every nine months after first changing.
4. Frequently check the screw nuts of bolts fixing the electromagnet and locking plate, if any screw nut is loosening please fasten it asap.
5. Before operation, please check the connector of electromagnet, if it's loosening please fasten it; then do testing on top limit switch and photocell sensor, if it cannot work please fix the problem, and if cannot fix it please replace it.
6. The seal in hydraulic cylinder should be replaced every two years.
7. The roller and sliding block should be replaced every two years.
8. The valve element in solenoid valve and filter in power unit should be cleaned every half year.
9. If any noise comes out from electromagnet, please replace it asap.

C. Service

1. If the platform tilts right-and-left when lifting, please check and adjust the balance chains;
If the platform tilts fore-and-aft when lifting, first please check if vehicle is parked correctly; second check the perpendicularity of post, if the platform still tilts after the above mentioned works please replace the roller.
2. If the platform tilts right-and-left when descending, first please check if the mechanical locking plate at higher side is unlocked, please balance chains if the locking plate is unlocked. If the platform tilts fore-and-aft when descending, first please check if vehicle is parked correctly; second check the perpendicularity of post, if the platform still tilts after the above mentioned works please replace the roller.
3. Adjust the compensated flow control valve on the power unit, if the lifting/descending speed is too fast or too slow.
4. Check if the emergency stop button is open and air switch is closed, if the equipment doesn't lift up when keep turning UP.
5. Check if the solenoid valve is open, if the platform only lift up but not descend, or it don't move at all when keep turning DOWN.
6. Check if the electromagnet is working to make the mechanical locking plate unlocked, if the platform lifts up first then descends but stop on the locking tab when keep turning DOWN.
7. Check if the electromagnet is working to make the mechanical locking plate unlocked, if the platform descends only but then stop on the locking tab when keep turning DOWN.
8. Check if the photocell sensor works correctly if the platform only descends with buzzer and warning light on when keep turning DOWN and the platform is above 500mm height.
9. Open the vent valve on the cylinder to make some air inside of cylinder released, if the platform jounces when lifts up
10. How to get the equipment balance:
Lift the platform up to any locking tab above 500mm height;
Manually open the manual switch of solenoid valve on power unit to make platform descend;
Keep turning on the manual switch of solenoid valve until both two mechanical locking plates on two sides of carriages fall on the bottom of the locking tabs on same level
Tighten or loosen the screw on adjustable screw to adjust the tightening or sag balance chains, to make the platform in balance during operation.

Foundation Diagram

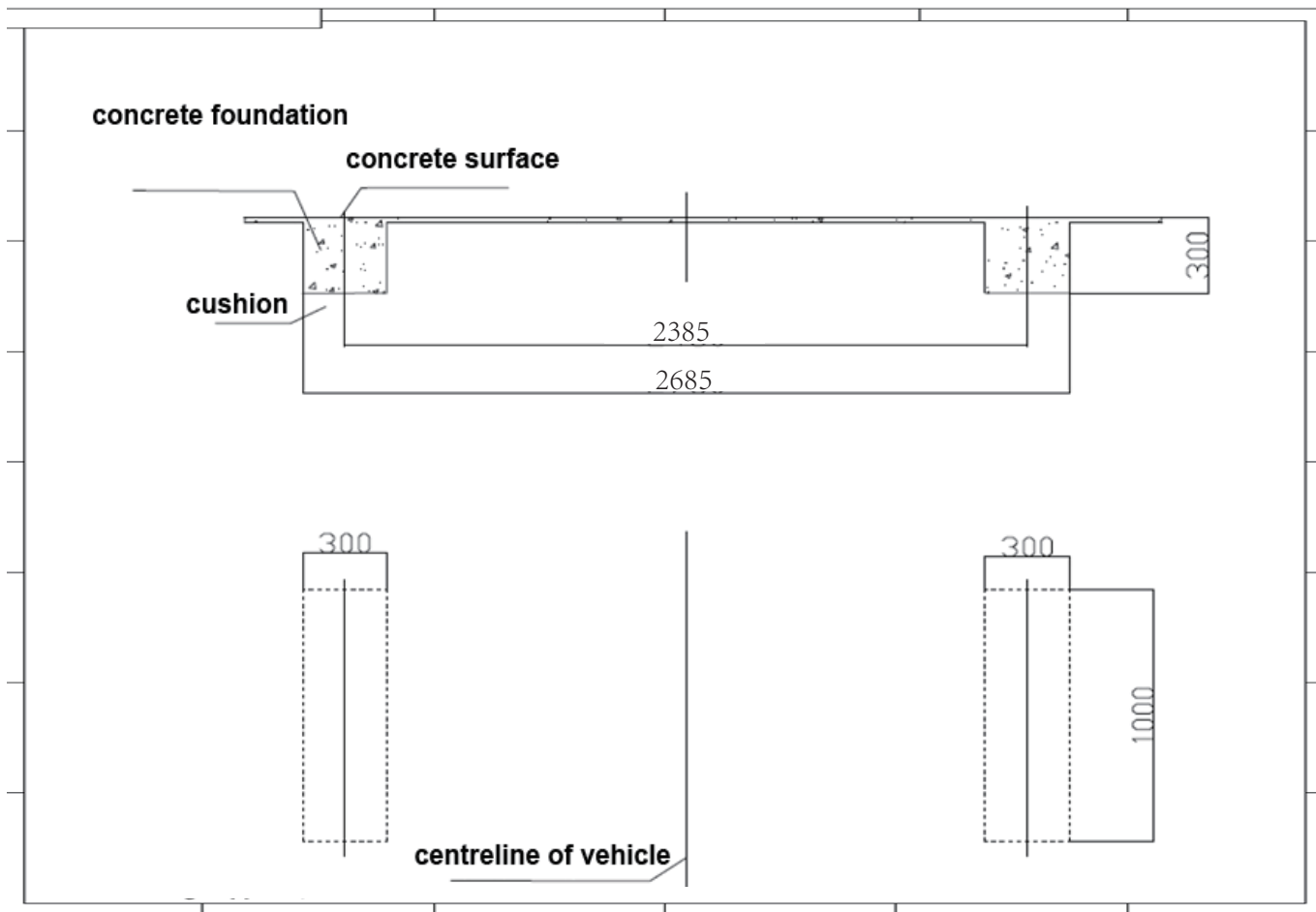

1. Tolerance of levelness must be below 5mm, compressive strength of concrete must be above 200kg/cm².
2. Thickness must be above 300mm and strength grade must be more than 250.
3. Ensure the new concrete be cured by at least 28 days minimum.
4. DO NOT install this lift on any asphalt surface or any surface other than concrete.
5. DO NOT install this lift on expansion seams or on cracked or defective concrete.
6. DO NOT install this lift on a second/elevated floor without first consulting building architect.
7. DO NOT install this lift outdoors unless special consideration has been made to protect the power unit from in climate weather conditions.
8. Leave enough space for the control cabinet.
9. Always use architect's plans when available. Check layout dimension against floorplan requirements making sure that adequate space is available.
10. The area where the lift will be located should be free of overhead obstructions such as heaters, building supports, electrical lines etc.

-damage caused by rain, excessive humidity, corrosive environments or other contaminants.
-any change or modification made to the equipment without pre-agreed.

These warranties do not extend to any cosmetic defect not interfering with equipment functionality or any incidental, indirect, or consequential loss, damage, or expense that may result from any defect, failure, or malfunction of a product or the breach or delay in performance of the warranty.

This warranty is exclusive and in lieu of all other warranties expressed or implied.

We make no warranty on components and/or accessories furnished to us by third parties. These are warranted only to the extent of the original manufacturer's warranty. Other items not listed but may be considered general wear parts.

We reserve the right to make design changes or add improvements to its product line without incurring any obligation to make such changes on product sold previously.

Warranty adjustments within the above stated policies are based on the model and serial number of the equipment. This data must be furnished with all warranty claims.

Trouble Shooting

| Trouble | Cause | Remedy |
|--|--|---|
| Motor does not run. | <ol style="list-style-type: none"> 1.Check fuse or circuit breaker. 2.Check for correct voltage to motor. 3.Inspect all wiring connections. 4.Switch burned out. 5.Motor windings burned out. | <ol style="list-style-type: none"> 1.Replace blown fuse or reset circuit breaker.* 2.Supply correct voltage to motor.* 3.Repair and insulate all connections.* 4.Replace switch.* 5.Replace motor* |
| Motor runs but will not raise lift. | <ol style="list-style-type: none"> 1.Open lowering valve. 2.Pump sucking air. 3.Suction stub off pump. 4.Low fluid level. 5.Lift Valve not opening. | <ol style="list-style-type: none"> 1.Repair or replace lowering valve.* 2.Tighten all suction line fittings.* 3.Replace suction stub.* 4.Fill tank with Dexron III ATF. 5.Repair or replace lift valve.* |
| Motor runs—raises unloaded lift but will not raise vehicle. | <ol style="list-style-type: none"> 1.Motor running on low voltage. 2.Trash in lowering valve. 3.Improper relief valve adjustment. 4.Overloading lift. | <ol style="list-style-type: none"> 1.Supply correct voltage to motor.* 2.Clean lowering valve.* 3.Replace relief valve cartridge.* 4.Check vehicle weight and/or balance vehicle weight on lifts. |
| Lift slowly settles down. | <ol style="list-style-type: none"> 1.Trash in check valve seat. 2.Trash in lowering valve seat. 3.External fluid leaks. | <ol style="list-style-type: none"> 1.Clean check valve.* 2.Clean lowering valve.* 3.Repair external leaks. |
| Slow lifting speed or fluid blowing out filler breather cap. | <ol style="list-style-type: none"> 1.Air mixed with fluid. 2.Air mixed with fluid suction. 3.Fluid return tube loose. 4.Cold Fluid | <ol style="list-style-type: none"> 1.Change hydraulic fluid to Dexron III ATF. 2.Tighten all suction line fittings.* 3.Reinstall fluid return tube.* 4.Contact Rotary for optional heater.* |
| Lift going up unlevel. | <ol style="list-style-type: none"> 1.Chains out of adjustment. 2.Lift installed on unlevel floor. | <ol style="list-style-type: none"> 1.Adjust slack out of chains per installation instructions. 2.Level lift per installation instructions. |
| Lift stops short of full rise or chatters. | <ol style="list-style-type: none"> 1. Low on fluid. | <ol style="list-style-type: none"> 1. Check fluid level and bleed cylinder If fluid is required inspect all fittings, hoses, and seals. Repair as required. Clean power unit pickup stub filter.* |
| Lift will not lower. | <ol style="list-style-type: none"> 1.Latches out of adjustment. 2.Lowering valve not open. 3.Lift valve not open. | <ol style="list-style-type: none"> 1.Check latches and adjust per install instructions. 2.Repair or replace lowering valve. 3.Repair or replace lift valve. |
| Cylinder will not retract. | <ol style="list-style-type: none"> 1. Velocity valve needs to be reset. | <ol style="list-style-type: none"> 1. Pressurize with power unit to reset the velocity valve and then repeat Oil Filling & Bleeding per install instructions. |



Remedy listed above may require qualified repair technician. Contact us for instructions.

Warranty

Our parking equipment has 10 years warranty on structure, and three year warranty on the whole machine. Within the warranty period, we are responsible for the parts and structure, not including labor nor any other cost unless pre-agreed.

Power units, hydraulic cylinders, and all other assembly components such as slip plates, cables, chains, valves, switches etc, are warranted for one year against defects in material or workmanship under normal use. We shall repair or replace at their option for the warranty period those parts returned to the factory freight prepaid which prove upon inspection to be defective. We will not be responsible on any labor costs unless pre-agreed. We will not responsible for the modification or upgrade of the product from the client unless pre-agreed.

These warranties do not extend to...

- defects caused by ordinary wear, abuse, misuse, shipping damage, un-proper installation, voltage or lack of required maintenance;
- damages resulting from purchaser's neglect or failure to operate products in accordance with instructions provided in the owner's manual(s) and/or other accompanying instructions supplied;
- normal wear items or service normally required to maintain the product in a safe operating condition;
- any component damaged in shipment;
- other items not listed but may be considered general wear parts;

Q&A

1. How many cars could be parked for each unit?
2 cars. One is on the ground and another is on the platform.
2. Could Hydro-Park 1127 be used for parking SUV?
Yes, the rated capacity of Hydro-Park 1127 is 2700kg, and maximum capacity is 3000kg, all types of SUV can be available.
3. Can Hydro-Park 1127 be used outdoor?
Hydro-Park 1127 is capable for both indoor and outdoor use . The finishing is powder coating and plate cover is galvanized, with rust-proof and rain-proof. When used indoor, you need consider the ceiling height.
4. What's the supply voltage?
Standard voltage is 220v, 50/60Hz, 1Phase. Other voltages could be customized according to clients' request.
5. Is the operation easy?
Yes. Keep holding the key switch to operate the equipment, which will stop at once if your hand releases.
6. Can this product still operate if electricity failure happens?
The platform can be descended even if there is no electricity. Firstly you need manually keep two electromagnetic lock retrieve to release the mechanical anti-falling lock, meanwhile the solenoid valve on the power unit can be opened manually to make hydraulic oil go back to oil tank, then the platform will descend by gravity.

Important notice

About the customized size:

If the size of the platform need to be customized based on customer require, difficulties might arise when entering or exiting the cars on the parking units. This depends on car type, the access and the individual driving behavior.

Operating device:

The position of the operating device depends on the project (switch post, house wall). From bottom of the shaft to the operating device an empty pipe DN40 with taut wire is necessary.

Temperature:

The installation is designed to operate between +5°and +40°C. Atmospheric Humidity: 50% at +40°C. If the lol circumstances differ from the above please contact Materials Handling.

Illumination:

Illumination has to be considered acc. to local requirements by client. Illumination in the shaft for maintenance is required to be minimum 80 Lux.

Maintenance:

Regular maintenance by qualified personnel can be provided by means of an Annual Service Contract.

Protection against corrosion:

Independent of a maintenance workings has to be carried out acc. to Cleaning and Maintenance Instruction regularly. Clean up galvanized parts and platforms of dirt and road salt as well as other pollution (corrosion danger)! Pit must be always ventilated well.

We reserve the right to change this specification without further notice!

We reserves the right in the course of technical progress to use newer or other technologies, systems, processes, procedures or standards in the fulfillment of their obligations other than those originally offered provided the customer derives no disadvantage from their so doing.

Reference



MATERIALS
Handling *Working with ease...*
PTY LTD

Our website: www.materialshandling.com.au
Phone us: 1300 65 00 35 Fax us: 1800 68 68 96
Email us: sales@materialshandling.com.au

Australia Wide Sales and Service